

ART.

5CA.551.000C.62

- Pinza a muro
- Wall panel holder
- Pince à mur
- Oberer Halter zur Wandbefestigung
- pinza a pared para panel
- Muur houder

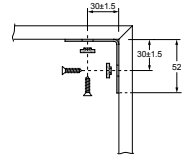
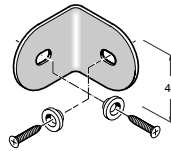

ART.

5CA.552.0000.62

- Angolare per fissaggio
- Angle bracket to fix panels
- Equerre de fixation
- Winkel zur Befestigung Panele
- Escuadra para fijación de paneles
- Paneel bevestigingshoek

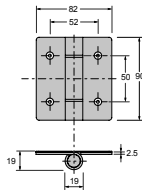
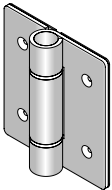

ART.

5CA.553.0000.62

- Cerniera coplanare
- Coplanar hinge
- Charnière applique
- Gleitscharnier für Panele
- Bisagra normal para paneles
- Scharnier voor paneel deur

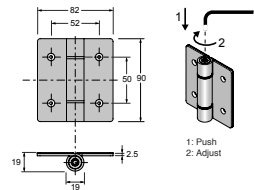
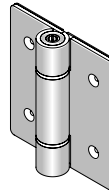

ART.

5CA.554.000C.62

- Cerniera coplanare autochiudente
- Self closing coplanar hinge
- Charnière Applique de fermeture automatique
- Gleitscharnier selbstschließend für Panele
- Bisagra con resorte para paneles
- Scharnier voor zelfsluitende paneel deur

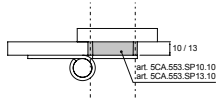

ART.

5CA.553.SP10.10

5CA.553.SP13.10

- Spessore sagomato per cerniere
- Shaped shim for hinges
- Cale de forme pour charnière
- Geformte Dichtung für Scharnier
- Espaciador conformado para bisagras
- Verdikkingsplaatje op maat voor scharnieren

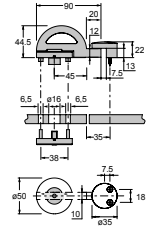
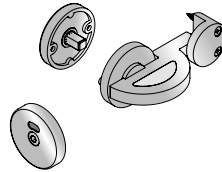

ART.

5CA.558.0000.62

- Chiusino libero/occupato con chiusura su fermo
- Snib with vacant/engaged indicator and spindle
- Dispositif de fermeture libre/occupé avec tige de fermeture sur gache
- Frei-Besetzt Garnitur mit feststehender Verriegelung
- Muletilla libre/ocupado con varilla de cierre sobre tope
- Vrij/bezet eenheid met grendel op sluitplaat

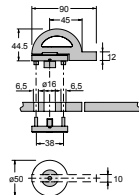
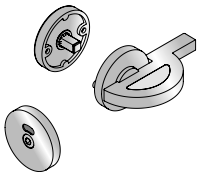

ART.

5CA.558.00LE.62

- Chiusino libero/occupato
- Snib with vacant/engaged indicator
- Dispositif de fermeture libre/occupé
- Frei-Besetzt Garnitur
- Muletilla libre/ocupado
- Vrij/bezet garnituur

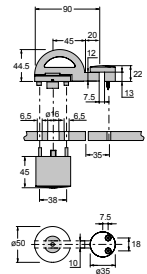
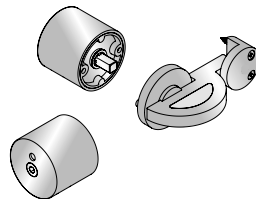

ART.

5CA.559.0000.62

- Chiusino libero/occupato con chiusura su fermo e pomolo
- Snib with vacant/engaged indicator, locking lever and door knob
- Dispositif de fermeture libre/occupé avec gache et bouton
- Frei-Besetzt Garnitur mit feststehender Verriegelung und Türkнопf
- Muletilla libre/ocupado con varilla de cierre sobre tope y pomolo
- Vrij/bezet eenheid met knop en grendel

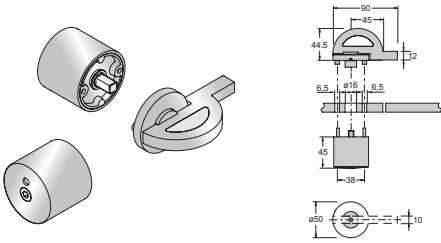

ART.

5CA.559.00LE.62

- Chiusino libero/occupato con pomolo
- Snib with vacant/engaged indicator and knob
- Dispositif de fermeture libre/occupé avec bouton
- Frei-Besetzt Garnitur mit Türknopf
- Muletilla libre/ocupado con pomo
- Vrij/bezet garnituur

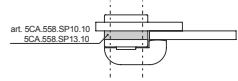
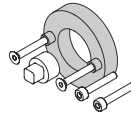

ART.

5CA.558.SP10.10 (10 mm)
5CA.558.SP13.10 (13 mm)

- Spessore sagomato per chiusini
- Shaped shim for snib indicators
- Cale de forme pour verrou
- Geformte Dichtung für Verriegelung
- Espaciador conformado para muletillas
- Verdikkingsplaatje op maat voor WC vergrendeling

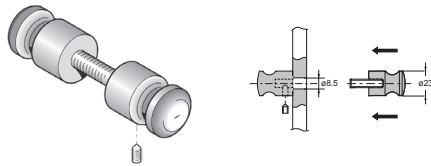

ART.

5CA.564.000D.62

- Pomolo doppio e fisso
- Double fixed knob
- Bouton double et fixe Doppelter
- Türknopf für Panele
- Doble pomo para panel
- Vaste knop dubbel

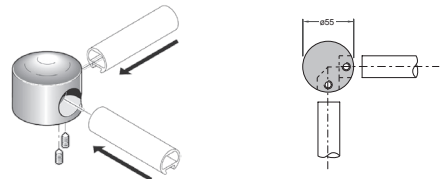

ART.

5CA.556.0000.62

- Giunto a 90° a 2 vie, per unione art.5CA.560.0000
- 90° top joint, two way, to suit art.5CA.560.0000
- Raccord 90° 2 voies, pour union art.5CA.560.0000
- Verbindungselement 25mm - Rohr 25mm 2 seitig 90°
- Codo 90° - tubo 25mm
- Hoekverbinding 90°

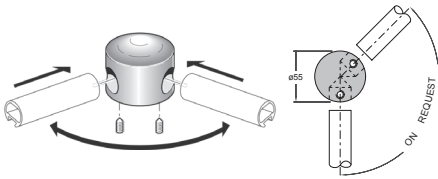

ART.

5CA.557.0000.62

- Giunto, con angolo a richiesta, a 2 vie, per unione art.5CA.560.0000
- Universal top joint, two way, to suit art.5CA.560.0000
- Raccord, avec angle sur demande, 2 voies, pour union art.5CA.560.0000
- Verbindungselement 25mm - Rohr 25mm 2 seitig, Winkel auf Anfrage
- Codo especial angulo a medida- tubo 25mm
- Verbindingsstuk 2 buizen 2 richtingen - hoek volgens opgave

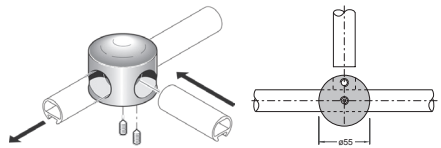

ART.

5CA.561.0000.62

- Giunto a 3 vie per unione art.5CA.560.0000
- Top joint, 3 way, for art.5CA.560.0000 connection
- Raccord - tube 3 voies pour union art.5CA.560.0000
- Verbindungselement 25mm - Rohr 25mm 3 seitig
- Unión en T - tubo 25mm
- Verbindingsstuk 3 wegs voor Alu buis

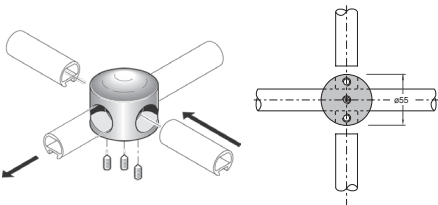

ART.

5CA.561.000B.62

- Giunto a 4 vie per unione art.5CA.560.0000
- Top X-joint, four way, for art.5CA.560.0000 connection
- Raccord - tube 4 voies pour union art.5CA.560.0000
- Verbindungselement 25mm - Rohr 25mm 4 seitig
- Unión en X cruce para tubo 25mm
- Verbindingsstuk 4 wegs voor Alu buis

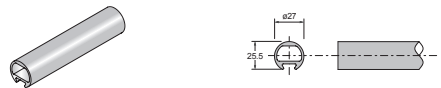

ART.

5CA.560.0000.62

- Tubo superiore in barre da 3 metri
- Top rail tube, 3 metres long
- Tube supérieur de support, 3 mètres
- Oberes Stützrohr 25mm, 3 Meter
- Tubo superior de soporte, diámetro 25mm, 3 metros
- Bovenbuis aluminium 3 meter

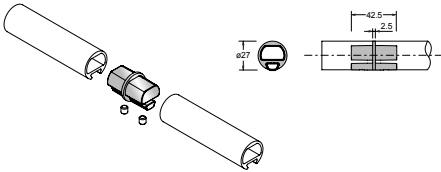

ART.

5CA.563.0000.62

- Giunzione per unione art.5CA.560.0000 con art.5CA.560.0000
- Tube connector, for art.5CA.560.0000 connection
- Raccord tube art.5CA.560.0000 avec art.5CA.560.0000
- Expansions - Verbindungselement Rohr 25mm - Rohr 25mm
- Unión para tubo 25mm - tubo 25mm de expansión
- Vaste knop

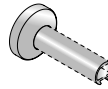

ART.

5CA.555.0000.62

- Rosetta per fissaggio art.5CA.560.0000 a parete
- Tube-wall fixing rose suitable for art.5CA.560.0000
- Rosace de fixation pour art.5CA.560.0000 à paroi
- Befestigungsrosette Rohr 25mm auf Mauer
- Roseta de fijación de tubo 25mm en pared
- Rozet voor muurbevestiging buis

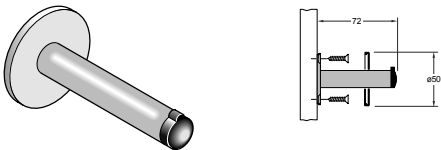

ART.

5CA.562.0000.62

- Appendiabiti/fermaporta
- Door-stop and clothes hook
- Butoir portemanteau
- Türstopper
- Tope de puerta colgador
- kapstok-deurstop

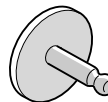

ART.

5CA.588.0000.62

- Appendiabiti
- Cloth hook
- Portemanteau
- Kleiderhaken einfach
- Colgador para panel
- Kapstok

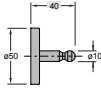
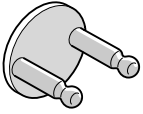

ART.

5CA.588.000D.62

- Appendiabiti
- Cloth hook
- Portemanteau
- Kleiderhaken einfach
- Colgador para panel
- Kapstok

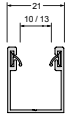

ART.

5CA.593.0000.62 (13 mm)

5CA.593.0010.62 (10 mm)

- Profilo in alluminio per fissaggio pannello/parete e guarnizione in PVC
- Door edge, aluminium profile for fixing panel-wall and door Seal in PVC
- Profil de feuillure en aluminium pour fixation panneau-paroi et joint de feuillure en PVC
- Aluminium Anschlagprofil für Befestigung Paneel-Wand und Anschlagdichtung
- Perfil de alluminio por fijaciones panel-pared y Guarnición en PVC
- Aluminium bevestigingsprofiel voor paneel-wand en guarnición en PVC

INFORMAZIONI TECNICHE

TECHNICAL INFORMATION

TECHNISCHE INFORMATIONEN

INFORMATIONS TECHNIQUES

TECHNISCHE INFORMATIE

IT				* colori indicativi				GB				* indicative colors				FR				* couleurs indicatives							
CODICE - CODE	MATERIALE	FINITURA	.XX *	MATERIAL	FINISH	.XX *	MATERIEL	FINITION	.XX *	MATERIAL	FINISH	.XX *	MATERIEL	FINITION	.XX *	MATERIAL	FINISH	.XX *	MATERIEL	FINITION	.XX *						
01T. KLO.V 2CC. KLO. 2CE. KLS. 2CP. KLH. 2CF. KLP. 2DM. KLR. EDS. 5CG. HGL. 5CS. HGU. 400-SS 400-HR-SS	ACCIAIO INOX AISI 316L	Di produzione: SATINATO	.44	A richiesta: LUCIDO	Copper Bronze Bright	.89	PVD su articoli selezionati (*)	Copper Bronze Satin Champagne Satin	.91	Black Satin Black Bright Chocolate Satin	.93 .94 .95	AISI 316L	A richiesta: LUCIDO	Wenge Frassinio Mogano	.46 .47 .48	+ LEGNO	A richiesta: LUCIDO + LEGNO	Wenge Frassinio Mogano	.49 .50 .51	ACCIAIO INOX AISI 316L + LEGNO	Di produzione: SATINATO + LEGNO	Nero Beige Marrone Rosso	.4A .4B .4C .4D	+ PELLE	A richiesta: LUCIDO + PELLE	Nero Beige Marrone Rosso	.3A .3B .3C .3D
		Di produzione: SATINATO + PELLE	Nero Beige Marrone Rosso		.4A .4B .4C .4D																						
		A richiesta: LUCIDO + PELLE	Nero Beige Marrone Rosso		.3A .3B .3C .3D																						
		Di produzione: ANODIZZATO SATINATO ELOX SATINATO A richiesta: VERNICIATO	Champagne Bronzo Nero		.66 .67 .68	ALLUMINIO		Di produzione: ANODIZZATO SATINATO ELOX SATINATO A richiesta: VERNICIATO	Champagne Bronzo Nero		.66 .67 .68																
		Di produzione: ANODIZZATO SATINATO ELOX SATINATO A richiesta: VERNICIATO	Champagne Bronzo Nero		.66 .67 .68																						
Di produzione: ANODIZZATO SATINATO ELOX SATINATO A richiesta: VERNICIATO	Champagne Bronzo Nero	.66 .67 .68																									
Di produzione: ANODIZZATO SATINATO ELOX SATINATO A richiesta: VERNICIATO	Champagne Bronzo Nero	.66 .67 .68																									
Di produzione: ANODIZZATO SATINATO ELOX SATINATO A richiesta: VERNICIATO	Champagne Bronzo Nero	.66 .67 .68																									
3CC	NYLON	Di produzione: BIANCO NERO	.01 .10	A richiesta: GIALLO BLU GRIGIO VERDE ROSSO	Yellow Blue Grey Green Red	.04 .06 .07 .08 .09	NYLON	Di produzione: BIANCO NERO	.01 .10	A richiesta: GIALLO BLU GRIGIO VERDE ROSSO	Yellow Blue Grey Green Red	.04 .06 .07 .08 .09															
		Di produzione: BIANCO NERO	.01 .10																								
		A richiesta: GIALLO BLU GRIGIO VERDE ROSSO	Yellow Blue Grey Green Red		.04 .06 .07 .08 .09																						
		Di produzione: BIANCO NERO	.01 .10																								
		A richiesta: GIALLO BLU GRIGIO VERDE ROSSO	Yellow Blue Grey Green Red		.04 .06 .07 .08 .09																						
M18	ALLUMINIO	Di produzione: VERNICIATO Bianco 1013 Bianco 9010	.26 .21 .30	ANODIZZATO GREZZO A richiesta: ANODIZZATO	Black White 1013 White 9010 Silver Unfinished Bronze Black	.26 .21 .30 .62 .61 .63 .64	ALUMINIUM	Standard: POWDER COATED ANODIZED UNFINISHED Upon Request: ANODIZED	Black White 1013 White 9010 Silver Unfinished Bronze Black	.26 .21 .30 .62 .61 .63 .64																	
		Di produzione: VERNICIATO Bianco 1013 Bianco 9010	.26 .21 .30																								
		ANODIZZATO GREZZO A richiesta: ANODIZZATO	Black White 1013 White 9010 Silver Unfinished Bronze Black		.26 .21 .30 .62 .61 .63 .64																						
		Standard: POWDER COATED ANODIZED UNFINISHED Upon Request: ANODIZED	Black White 1013 White 9010 Silver Unfinished Bronze Black		.26 .21 .30 .62 .61 .63 .64																						
		Di produzione: VERNICIATO Bianco 1013 Bianco 9010	.26 .21 .30																								
PVD	ACCIAIO INOX AISI 316L	PVD LUCIDO	.81	Oro	Gold	.81	AISI 316L	BRIGHT PVD	Gold	.81																	
		PVD LUCIDO	.81																								
		Oro	.81																								
		BRIGHT PVD	Gold		.81																						
		Gold	.81																								
5CA 5CN	ALLUMINIO NYLON	ANODIZZATO	.62	Argento Bianco GRIGIO ROSSO NERO	Silver White Grey Red Black	.62 .01 .07 .09 .10	ALUMINIUM NYLON	ANODIZED Standard: WHITE GREY RED BLACK	Silver White Grey Red Black	.62 .01 .07 .09 .10																	
		ANODIZZATO	.62																								
		Argento Bianco GRIGIO ROSSO NERO	Silver White Grey Red Black		.62 .01 .07 .09 .10																						
		ANODIZED Standard: WHITE GREY RED BLACK	Silver White Grey Red Black		.62 .01 .07 .09 .10																						
		Silver White Grey Red Black	.62 .01 .07 .09 .10																								
5CM	ACCIAIO INOX AISI 316L + NYLON	Di produzione: SATINATO NERO	.44 .10	NERO	Black	.44 .10	AISI 316L + NYLON	Standard: SATIN BLACK	Black	.44 .10																	
		Di produzione: SATINATO NERO	.44 .10																								
		NERO	Black		.44 .10																						
		Standard: SATIN BLACK	Black		.44 .10																						
		Black	.44 .10																								
400-NY 400-HR-NY	NYLON	BIANCO PLUS BIANCO BISCOTTO GIALLO PASTELLO GIALLO BLU PASTELLO BLU GRIGIO VERDE ROSSO NERO	.A1 .01 .02 .03 .04 .05 .06 .07 .08 .09 .10	GIALLO BLU GRIGIO VERDE ROSSO NERO	Yellow White Light Yellow Yellow Light Blue Blue Grey Green Red Black	.A1 .01 .02 .03 .04 .05 .06 .07 .08 .09 .10	NYLON	WHITE PLUS WHITE BISCOTT LIGHT YELLOW YELLOW LIGHT BLUE BLUE GREY GREEN RED BLACK	White Plus White Light Yellow Yellow Light Blue Blue Grey Green Red Black	.A1 .01 .02 .03 .04 .05 .06 .07 .08 .09 .10																	
		BIANCO PLUS BIANCO BISCOTTO GIALLO PASTELLO GIALLO BLU PASTELLO BLU GRIGIO VERDE ROSSO NERO	.A1 .01 .02 .03 .04 .05 .06 .07 .08 .09 .10																								
		GIALLO BLU GRIGIO VERDE ROSSO NERO	Yellow Blue Grey Green Red Black		.A1 .01 .02 .03 .04 .05 .06 .07 .08 .09 .10																						
		WHITE PLUS WHITE BISCOTT LIGHT YELLOW YELLOW LIGHT BLUE BLUE GREY GREEN RED BLACK	White Plus White Light Yellow Yellow Light Blue Blue Grey Green Red Black		.A1 .01 .02 .03 .04 .05 .06 .07 .08 .09 .10																						
		White Plus White Light Yellow Yellow Light Blue Blue Grey Green Red Black	.A1 .01 .02 .03 .04 .05 .06 .07 .08 .09 .10																								
CAP	ALLUMINIO VERNICIATO	BIANCO GRIGIO	.30 .24	GRIGIO	Grey	.30 .24	ALUMINIUM LAQUE	Standard: WHITE GREY	White Grey	.30 .24																	
		BIANCO GRIGIO	.30 .24																								
		GRIGIO	Grey		.30 .24																						
		Standard: WHITE GREY	White Grey		.30 .24																						
		White Grey	.30 .24																								
400-ALU	ALLUMINIO TUBO ACCESSORI SUPPORTI E CURVE	Alluminio anodizzato bronzo chiaro Nylon grigio	.70	Lega verniciata grigio metallizzato	Aluminum anodized light bronze Nylon grey	.70	ALUMINIUM TUBE ACCESSOIRES SUPPORTS ET COUDES	Aluminum anodized light bronze Nylon grey	Aluminum anodized light bronze Nylon grey	.70 .70																	
		Alluminio anodizzato bronzo chiaro Nylon grigio	.70																								
		Lega verniciata grigio metallizzato	Aluminum anodized light bronze Nylon grey		.70 .70																						
		Aluminum anodized light bronze Nylon grey	Aluminum anodized light bronze Nylon grey		.70 .70																						
		Aluminum anodized light bronze Nylon grey	Aluminum anodized light bronze Nylon grey		.70 .70																						
400-ALU	ALLUMINIO TUBO ACCESSORI SUPPORTI E CURVE	Alluminio anodizzato argento Nylon bianco	.71	Lega verniciata bianco	Aluminum anodized silver Nylon white	.71	ALUMINIUM TUBE ACCESSOIRES SUPPORTS ET COUDES	Aluminum anodized silver Nylon white	Aluminum anodized silver Nylon white	.71 .71																	
		Alluminio anodizzato argento Nylon bianco	.71																								
		Lega verniciata bianco	Aluminum anodized silver Nylon white		.71 .71																						
		Aluminum anodized silver Nylon white	Aluminum anodized silver Nylon white		.71 .71																						
		Aluminum anodized silver Nylon white	Aluminum anodized silver Nylon white		.71 .71																						

DE			ES			NL						
* indicative farben			* colores indicativos			* indicatieve colors						
MATERIAL	AUSFÜHRUNG	.XX *	MATERIAL	ACABADO	.XX *	MATERIAAL	AFWERKINGEN	.XX *				
EDELSTAHL ROSTFREI WERKSTOFF 1.4404	Standard: FEIN MATT SATINIERT	.44	ACERO INOXIDABLE AISI 316L	Estándar: MATE	.44	ROESTVAST STAAL AISI 316L	Standaard: MAT GEBORSTELD	.44				
	Auf Anfrage: HOCHGLANZ POLIERT	.43		Bajo pedido: BRILLO	.43		Op aanvraag: BLINKEND GEBORSTELD	.43				
	Auf Anfrage: PVD	.89		Bajo pedido: Copper Bronze Bright	.89		Op aanvraag: MET PVD	Copper Bronze Bright	.89			
	BESCHICHTET an sellierfen Produkten (*)	.90		Copper Bronze Satin Champagne Satin	.90		BEHANDELING voor geselecteerde Artikelen (*)	Copper Bronze Satin Champagne Satin	.90			
	Black Satin	.91		Black Satin	.91		Black Satin	.91				
Black Bright	.94	Black Bright	.94	Black Bright	.94							
Chocolate Satin	.95	Chocolate Satin	.95	Chocolate Satin	.95							
EDELSTAHL ROSTFREI WERKSTOFF 1.4404 + MASSIVHOLZ	Standard: FEIN MATT SATINIERT + MASSIVHOLZ	.46	ACERO INOXIDABLE AISI 316L + MADERA	Estándar: MATE + MADERA	.46	ROESTVAST STAAL AISI 316L + HOUT	Standaard: MAT GEBORSTELD + HOUT	.46				
Auf Anfrage: HOCHGLANZ POLIERT + MASSIVHOLZ	.48	Bajo pedido: BRILLO + MADERA		.48	Op aanvraag: BLINKEND GEBORSTELD + HOUT		Wenge Es Mahonie	.48				
Wenge	.49	Wenge		.49	Wenge		.49					
Esche	.50	Fresno		.50	Es		.50					
Mahagoni	.51	Caoba		.51	Mahonie		.51					
EDELSTAHL ROSTFREI WERKSTOFF 1.4404 + LEDER	Standard: FEIN MATT SATINIERT + LEDER	.4A	ACERO INOXIDABLE AISI 316L + CUERO	Estándar: MATE + CUERO	.4A	ROESTVAST STAAL AISI 316L + LEDER	Standaard: MAT GEBORSTELD + LEDER	.4A				
Auf Anfrage: HOCHGLANZ POLIERT + LEDER	.4B	Bajo pedido: MADERA + CUERO		.4B	Op aanvraag: BLINKEND GEBORSTELD + LEDER		Wenge Beige Bruin Rood	.4B				
Schwarz	.4C	Negro		.4C	Zwart		.4C					
Crème	.4D	Beige		.4D	Beige		.4D					
Braun	.3A	Marrón		.3A	Rood		.3A					
Rot	.3B	Rojo	.3B	Zwart	.3B							
Schwarz	.3C	Negro	.3C	Beige	.3C							
Crème	.3D	Beige	.3D	Marrón	.3D							
Braun		Marrón		Rojo								
Rot		Rojo										
ALUMINIUM	Standard: ELOXIERT SATINIERT SATINIERT	.66	ALUMINIO	Estándar: ANODIZADO MATE MATE	.66	ALUMINIUM	Standaard: GEANODISEERD MAT GEBORSTELD Op aanvraag: GELAKT	.66				
Auf Anfrage: LACKIERT	.67	Bajo pedido: PINTADO		.67	Zwart		.67					
Champagne	.68	Champán		.68	Bronze		.68					
Dunkel Bronze		Negro			Zwart							
Schwarz		Negro			GELAKT							
NYLON	Standard: WEISS SCHWARZ Auf Anfrage: GELB BLAU GRAU GRÜN ROT	.01	NYLON	Estándar: BLANCO NEGRO Bajo pedido: AMARILLO AZUL GRIS VERDE ROJO	.01	NYLON	Standaard: WIT ZWART Op aanvraag: GEEL BLAUW GRIJS GROEN ROOD	.01				
Schwarz	.10	NEGRO		.10	Zwart		.10					
GELB	.04	AMARILLO		.04	GEEL		.04					
BLAU	.06	AZUL		.06	BLAUW		.06					
GRAU	.07	GRIS		.07	GRIJS		.07					
GRÜN	.08	VERDE	.08	GROEN	.08							
ROT	.09	ROJO	.09	ROOD	.09							
ALUMINIUM	Standard: LACKIERT	.26	ALUMINIO	Estándar: PINTADO	.26	ALUMINIUM	Standaard: GELAKT	.26				
Weiss 1013	.21	Blanco 1013		.21	Zwart		.21					
Weiss 9010	.30	Bianco 9010		.30	Wit 1013		.30					
ELOXIERT ROH	.62	ANODIZADO Plata		.62	Wit 9010		.62					
Auf Anfrage: ELOXIERT	.63	Bajo pedido: ANODIZADO		.63	GEANODISEERDMAT Zilver		.63					
Bronze	.64	Bronce	.64	BRUIT	.64							
Black		Negro		Op aanvraag: GEANODISEERDMAT Zwart								
EDELSTAHL ROSTFREI WE 1.4404	PVD BESCHICHTET	.81	ACERO INOXIDABLE AISI 316L	PVD BRILLO	.81	ROESTVAST STAAL AISI 316L	Met PVD BEHANDELING	.81				
Gold		Oro			Gold							
ALUMINIUM	ELOXIERT	.62		ALUMINIO	ANODIZADO		.62	ALUMINIUM	GEANODISEERDMAT	.62		
NYLON	Standard: WEISS GRAU ROT SCHWARZ	.01			NYLON		Estándar: BLANCO GRIS ROJO NEGRO		.01	NYLON	Standaard: WIT GRIJS ROOD ZWART	.01
Weiss	.07	GRIS					.07		GRIJS		.07	
GRAU	.09	ROJO	.09			ROOD	.09					
ROT	.10	NEGRO	.10			ZWART	.10					
SCHWARZ												
EDELSTAHL ROSTFREI WE 1.4404 + NYLON	Standard: SATINIERT SCHWARZ	.44	ACERO INOXIDABLE AISI 316L + NYLON	Estándar: MATE NEGRO	.44	ROESTVAST STAAL AISI 316L + NYLON	Standaard: SATINATO ZWART	.44				
Schwarz	.10	NEGRO		.10	ZWART		.10					
NYLON	WEISS PLUS	.A1		NYLON	BLANCO PLUS		.A1	NYLON	Standaard: WIT PLUS	.A1		
Weiss	.01	BLANCO			.01		WIT		.01			
CREME	.02	BEIGE			.02		BISCUIT		.02			
BLÜTENGELB	.03	AMARILLO PASTEL	.03		PASTEL GEEL	.03						
GELB	.04	AMARILLO	.04		GEEL	.04						
FLIEDERBLAU	.05	AZUL PASTEL	.05	PASTEL BLAUW	.05							
BLAU	.06	AZUL	.06	BLAUW	.06							
GRAU	.07	GRIS	.07	GRIJS	.07							
GRÜN	.08	VERDE	.08	GROEN	.08							
ROT	.09	ROJO	.09	ROOD	.09							
SCHWARZ	.10	NEGRO	.10	ZWART	.10							
BESCHICHTETEM ALUMINIUM	WEISS	.30	ALUMINIUM PINTADO	BLANCO	.30	GELAKT ALUMINIUM	WIT	.30				
GRAU	.24	GRIS		.24	GRIJS		.24					
ALUMINIUM ROHR ZUBEHÖRTEILE STÜTZE UND BÖGEN	Aluminium eloxiert lichtbronz Nylon Grau	.70		ALUMINIUM TUBO ACCESORIOS SOPORTES Y CURVAS	Aluminio anodizado bronce claro Nylon gris		.70	ALUMINIUM BUIS TOEBEHOREN STEUEN EN BOCHTEN	Aluminium geanodiseerd lichtbrons Nylon Grijs	.70		
Lackierte Legierung metallgrau		Lacado gris metalizado					Legering gelakt metallic grijs					
ALUMINIUM ROHR ZUBEHÖRTEILE STÜTZE UND BÖGEN	Aluminium eloxiert silber Nylon weiss	.71			ALUMINIUM TUBO ACCESORIOS SOPORTES Y CURVAS		Aluminio anodizado Nylon blanco		.71	ALUMINIUM BUIS TOEBEHOREN STEUEN EN BOCHTEN	Aluminium geanodiseerd zilver Nylon wit	.71
Lackierte Legierung weiss		Lacado blanco				Legering gelakt wit						

PROGRAMMA 500-ALU
MATERIALI IMPIEGATI - MATERIALS - MATÉRIAUX UTILISÉS - VERWENDETE MATERIELEN - MATERIALES EMPLEADOS - GEBRUIKTE MATERIELEN

Lega utilizzata di alluminio: 6060
 Trattamento superficiale: ossidazione anodica spessore 8-10 µm
 Stato metallurgico: T5

Aluminium - Legierungen: 6060
 Oberflächenbehandlung: anodische Oxydation 8-10 µm
 Werkstoffzustände: T5

Aluminium alloy employed in the manufacture of these products: 6060
 Surface treatment: anodic oxidation at a thickness of 8-10 µm
 Temper: T5

Aleación de aluminio utilizada: 6060
 Tratamiento superficial: oxidación anódica, grosor 8-10 µm
 Estados de tratamiento: T5

Alliage d'aluminium utilisé: 6060
 Traitement de surface: oxydation anodique, épaisseur 8-10 µm
 Etats métallurgiques: T5

Gebruikte aluminiumlegering 6060
 Oppervlaktebehandeling: anode-oxidatie dikte 8-10 µm
 Toestandsaanduidingen: T5

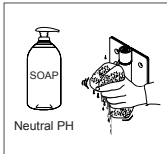

PULIZIA
MAINTENANCE
NETTOYAGE
REINIGINGSAANWIJZINGEN
LIMPIEZA
ONDERHOUD

PROGRAMMA 500-NY / 500-CM
MATERIALI IMPIEGATI - MATERIALS - MATÉRIAUX UTILISÉS - VERWENDETE MATERIELEN - MATERIALES EMPLEADOS - GEBRUIKTE MATERIELEN

- Resina termoplastica (Poliammide 6).
- Alta resistenza meccanica.
- Tenacità agli urti.
- Resistenza ad usura e abrasione.
- Classificata come autoestinguenta di categoria UL 94V-2.
 E non emana gas tossici.

- Thermoplastisches Harz (Polyamid 6):
- Hohe mechanische Widerstandsfähigkeit.
- Unzerstörbar gegenüber üblichen Schlagbeanspruchungen.
- Widerstandsfähigkeit gegen Verschleiss und Abnutzung durch Reibung.
- Selbstverlöschend in der Kategorie UL 94 V-2 klassifiziert.
 Es entstehen keine toxischen Gase.

- Thermoplastic resin (Polyamide 6).
- High mechanical resistance.
- Tenacity.
- Resistance to wear and abrasion.
- Classified as self-extinguishable into category UL 94V-2.
 It does not generate toxic gases.

- Resina de termoplástico (Poliamida 6).
- Alta resistencia mecánica.
- Resistencia contra impactos.
- Resistencia a desgaste y abrasión.
- Clasificada como auto-extinguible de clase UL 94V-2.
 Y no emana gas tóxicos.

- Résine thermoplastique (Polyamide 6).
- Résistance mécanique élevée.
- Grande résistance aux chocs.
- Résistance à l'usure et à l'abrasion.
- Classée comme auto-extinguible de catégorie UL 94V-2.
 Ne libère pas de gaz toxiques.

- POLYAMIDE 6 (thermoplastische kunststof)
- Hoge mechanische weerstand stootvast
- Gebruiksvriendelijk en onderhoudsvriendelijk
- Geklasseerd als zelfdovend onder categorie UL94V-S

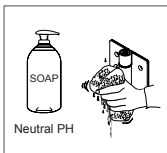

PULIZIA
MAINTENANCE
NETTOYAGE
REINIGINGSAANWIJZINGEN
LIMPIEZA
ONDERHOUD

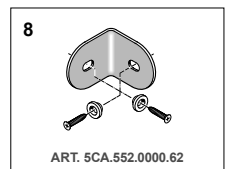
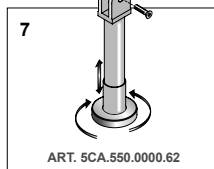
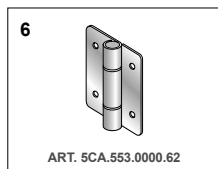
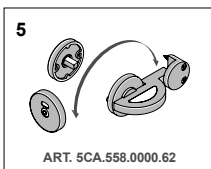
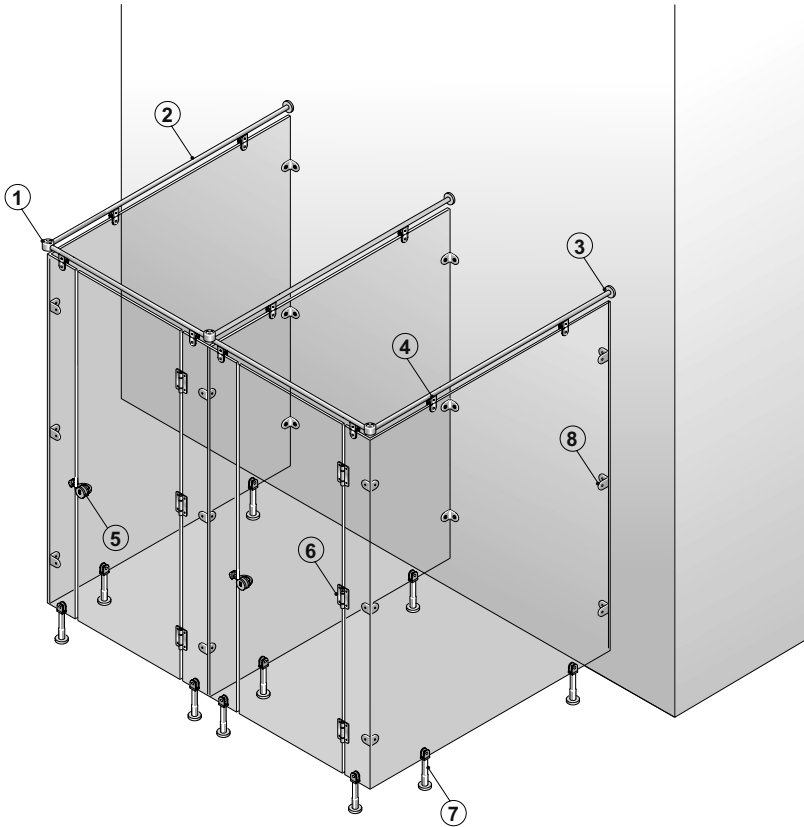
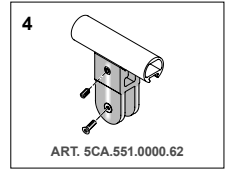
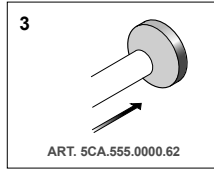
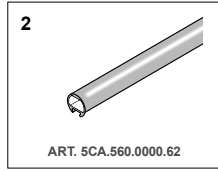
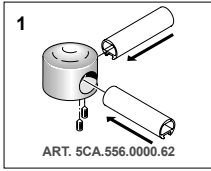

RILIEVO MISURE PER UNA CORRETTA INSTALLAZIONE DEL TUBO SUPERIORE / TAKING MEASUREMENTS FOR THE CORRECT INSTALLATION OF THE UPPER RAIL / PRISE DE MESURES POUR UNE INSTALLATION CORRECTE DU TUBE SUPERIEUR / MASSERMITTLUNG ZUR KORREKTEN INSTALLATION DES OBEREN STÜTZROHRES / TOMAR LAS MEDIDAS PARA INSTALAR CORRECTAMENTE EL TUBO SUPERIOR / AFMETINGEN VOOR EEN CORRECTE INSTALLATIE VAN DE BOVENSTE BUIS

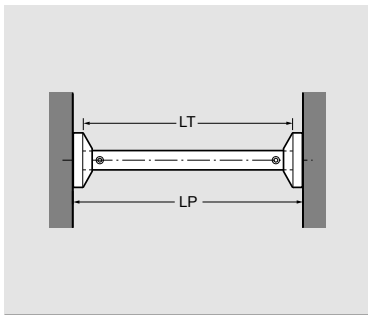

Unione Muro – Muro con articolo 5CA.555.0000
 Wall/Wall Connection with art. 5CA.555.0000
 Jonction paroi-paroi avec art. 5CA.555.0000
 Verbindung Wand-Wand mit Article 5CA.555.0000
 Unión pared-pared con artículos 5CA.555.0000
 Verbinding muur-muur met art. 5CA.555.0000

LP = Distanza tra muro e muro / Distance from wall to wall / Distance paroi-paroi
 Abstand zwischen den Wänden / Distancia entre paredes / Afstand tussen de muren

LT = Lunghezza del tubo da tagliare / Length of the tube to be cut / Longueur du tube à couper / Länge des geschnittenen Rohres / Longitud del tubo a cortar / Lengte van de af te korten buis

LT = LP - 26 mm

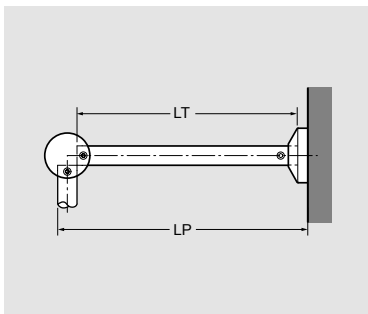

Unione ad angolo tra rosetta e giunto
 Elbow connection with rose and joint
 Jonction d'angle entre la rosace et le raccord
 Eckverbindung zwischen der Rosette und dem Verbindungselement
 Unión con roseta y unión
 Hoekverbinding tussen de rozet en de koppeling

LP = Distanza tra muro ed esterno tubo / Distance from wall to the end of the rail
 Distance entre la paroi et le bout du tube / Abstand zwischen Wand und Aussenrohr
 Distancia entre la pared y la extremidad del tubo / Afstand tussen de muur en het uiteinde van de buis

LT = Lunghezza del tubo da tagliare / Length of the tube to be cut / Longueur du tube à couper / Länge des geschnittenen Rohres / Longitud del tubo a cortar / Lengte van de af te korten buis

LT = LP - 40 mm

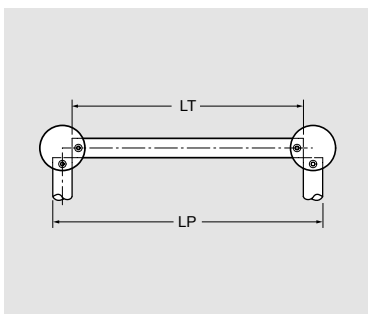

Unione tra giunti
 Elbow connection with joints
 Jonction des raccordes
 Verbindung zwischen den Verbindungselemente
 Conexión con ensamble
 Verbinding tussen de Koppelingen

LP = Distanza tra i due esterno tubo / Distance between the rails / Distance entre les deux bouts du tube / Abstand zwischen den beiden Aussenrohren / Distancia entre las dos extremidades del tubo / Afstand tussen de twee uiteinden van de buis

LT = Lunghezza del tubo da tagliare / Length of the tube to be cut / Longueur du tube à couper / Länge des geschnittenen Rohres / Longitud del tubo a cortar / Lengte van de af te korten buis

LT = LP - 56 mm

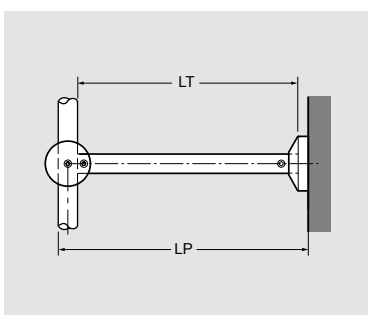

Connessione tra rosetta a muro e giunto a "T"
 Connection wall rose and T-joint
 Jonction entre la rosace sur la paroi et le joint en "T"
 Verbindung zwischen wandrosette und Verbindungselement in t-form
 Unión entre roseta de fijación en pared y unión en "T"
 Verbinding tussen de rozet en de T-koppeling

LP = Distanza tra muro ed esterno tubo / Distance from wall to rail / Distance entre la paroi et le bout du tube / Abstand zwischen der Wand und dem Aussenrohr
 Distancia entre la pared y la extremidad del tubo / Afstand tussen de muur en het uiteinde van de buis

LT = Lunghezza del tubo da tagliare / Length of the tube to be cut / Longueur du tube à couper / Länge des geschnittenen Rohres / Longitud del tubo a cortar / Lengte van de af te korten buis

LT = LP - 40 mm